

# Gocator® 2512

## 3D SMART LASER LINE PROFILE SENSOR



BLUE  
LASER

- OPTIMIZED OPTICAL DESIGN FOR SUPERIOR DATA ON SPECULAR SURFACES
- SCANS SPECULAR AND DIFFUSE TARGETS SIMULTANEOUSLY
- LOW SENSITIVITY TO TARGET ANGLE FOR INCREASED FLEXIBILITY OF SETUP
- HANDLES A WIDE VARIETY OF MATERIALS AND SURFACE TYPES

Gocator® 2512 is a specialized laser profiler for **high-precision 3D scanning of glass** and other specular materials including polished metals and plastics. Especially in consumer electronics (CE) assemblies, these materials are often embedded into the same housings, side by side. Gocator® 2512 has the unique ability to scan these **specular and diffuse** surfaces simultaneously. For example, the sensor can capture a cell phone's cover glass and its frame in a single scan. Gocator® 2512 also delivers exceptional performance in GD&T measurement of component assemblies with various challenging surface finishes (e.g., transparent, glossy).

### PRECISION-ENGINEERED FOR SCANNING GLASS AND OTHER SPECULAR SURFACES

#### HIGH-SPEED, HIGH-RESOLUTION SPECULAR SCANNING

Gocator® 2512 features an optimized optical design for superior glass scanning at 8 microns X resolution, 0.2 microns Z repeatability, and speeds up to 10 kHz (including scan, measure, and control).

#### SPECIALIZED LASER PROJECTION TECHNOLOGY

Gocator® 2512 uses specialized laser projection technology that can handle a wider range of sensor setups (i.e., target angles), material types, and surface colors. Competing laser profilers use a collimated laser beam that does not offer the same target angle performance.

#### FASTER, EASIER-TO-USE, MORE COST EFFECTIVE

Unique scanning capability, optimized optical design, and wide FOV on specular targets—combined with a smart all-in-one design—make Gocator® 2512 faster, easier to use, and more cost-effective than competing glass scanning technologies such as confocal scanners.



Gocator® 2512 scanning cell phone cover glass assembly

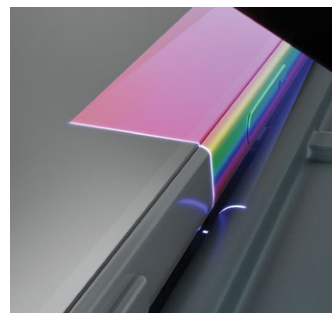

Generates high-resolution 3D data



Apply built-in measurement tools

## GOCATOR 2512

Data Points / Profile	1920
Resolution X (µm) (Profile Data Interval)	8.0
Linearity Z (+/- % of MR)	0.015%
Repeatability Z (µm)	0.2
Clearance Distance (CD) (mm)	17.0
Measurement Range (MR) (mm)	6
Field of View (FOV) (mm)	13.0 - 14.5
Laser Class	2 (blue, 405 nm)
Dimensions (mm)	46x80x110
Weight (kg)	0.65
Scan Rate	2.4 kHz (full field of view) to 10 kHz
Interface	Gigabit Ethernet
Inputs	Differential Encoder, Laser Safety Enable, Trigger
Outputs	2x Digital output, RS-485 Serial (115 kBaud)
Input Voltage (Power)	+24 to +48 VDC (15 Watts); Ripple +/- 10%
Housing	Gasketed aluminum enclosure, IP67
Operating Temperature	0 to 40°C
Storage Temperature	-30 to 70°C
Vibration Resistance	10 to 55 Hz, 1.5 mm double amplitude in X, Y, and Z directions, 2 hours per direction
Shock Resistance	15 g, half sine wave, 11 ms, positive and negative for X, Y, and Z directions
Scanning Software	Browser-based GUI and open source SDK for configuration and real-time 3D visualization. Open source SDK, native drivers, and industrial protocols for integration with user applications, third-party image processing applications, robots, and PLCs.

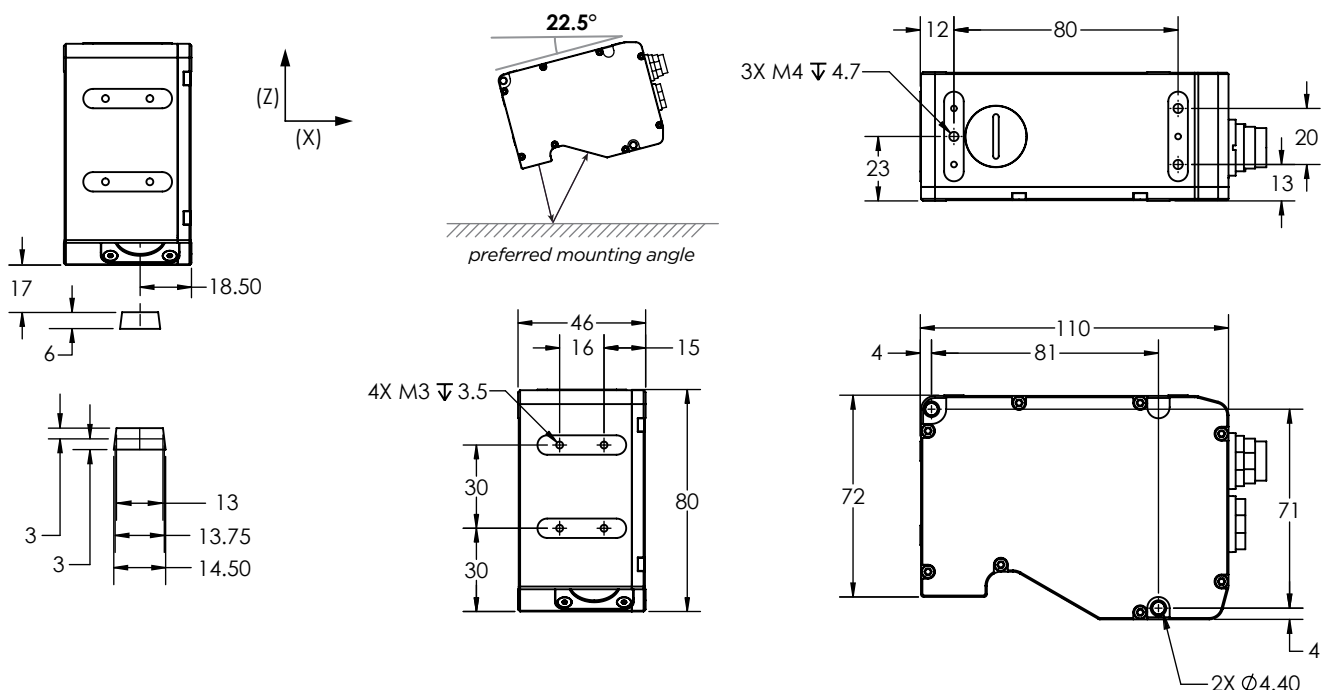

**STEMMER**<sup>®</sup>  
IMAGING